



SUN EARTH

THE SOLARAY-E SERIES

HOT WATER STATION SPECIFICATION SHEET

Applications



Solar Water Heating



Technical Specifications:

System	
Maximum Collector Area ¹	96 ft ²
Maximum Building Height ²	30 ft
Potable Plumbing Diameter	3/4"
Solar Electrical	
Maximum Power Input	87 Watts
Input Voltage	120 V
Backup Heating Element Electrical (Optional)	
Maximum Power Input	4500 Watts
Input Voltage	240 V

¹ Collectors plumbed in parallel. ² Based on 20 feet of piping to the collectors.

Materials

Tank:	Glass Lined Steel Vessel with 2" Non-CFC Foam Insulation
Heat Exchanger:	5/8" Nominal Copper Double Wall Tubing
Expansion Tank:	16 Gauge Cold Rolled Steel 100% Butyl Water Chamber Polypropylene Lined
Pump:	1/25 HP Cast Iron
Flex Lines:	Coated Stainless Steel Internal Dielectric Insulator

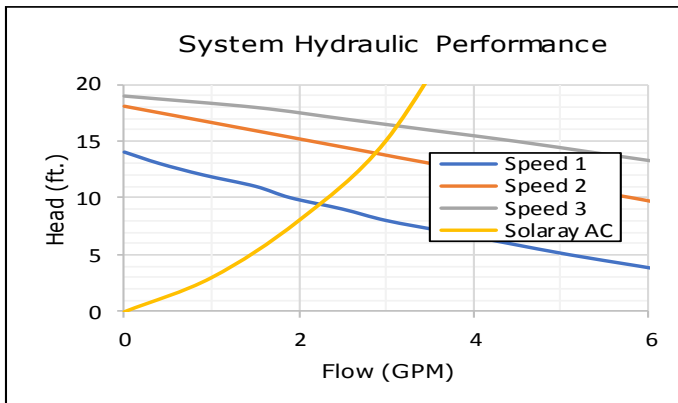

Models

Model Number	Description	Dimensions	Approx. Gross Weight
100004-9-80	SolaRay-E HWS 80 Gallon	70" x 30 ¹ / ₂ " x 24 ¹ / ₂ " (H,L,W)	198 lbs.
100004-9-120	SolaRay-E HWS 120 Gallon	75" x 32 ³ / ₄ " x 28 ¹ / ₄ " (H,L,W)	342 lbs.

Due to SunEarth's policy of continuous product improvement, specifications are subject to change without notice.



SUN EARTH

8425 Almeria Avenue Fontana, CA 92335
(909) 434-3100, Fax (909) 434-3101
www.sunearthinc.com



General:

The SunEarth SolaRay-E is a ready to install, pre-engineered hot water station (HWS) designed with seamless installation in mind. Factory assembled using top tier components and tested for hydraulic integrity. The SolaRay-E HWS contains all the components and safety devices necessary for SunEarth's high performing SolaRay AC indirect glycol system. Featuring an all copper, double walled heat exchanger, an adjustable three speed pump and manufactured by SunEarth, the SolaRay-E HWS is the installers obvious choice.

Hot Water Station Features:

1. **Tank:** Glass lined and pressure tested, includes a copper double wall protected heat exchange coil beneath the tanks R-17 insulation and painted metal jacket. The heat exchange storage tank is protected by a 150 psi/210°F relief valve.
2. **Controller:** Operates the pump through differential temperature algorithms, the Liquid Crystal Display (LCD) offers insight into the system operation and condition. The controller reports temperature readings from 3 distinct locations; (T1) collector, (T2) bottom of storage tank and (T3) top of storage tank.
3. **Thermal Expansion Tank:** Ensures consistent pressure throughout the wide operational temperature range. The NSF Standard 61 rated potable tank has a total volume of 2.1 gallons and an operational limit of 150 psi/200°F. The solar expansion tank has a total volume of 4.8 gallons and an operational limit of 150psi/240°F.
4. **Pump:** the high efficiency 1/25 cast iron pump uses couplings instead of union connections to avoid any potential leakage. The pump has a built-in cord for ease of installation.
5. **Thermometers:** Two thermometers with the range of 0° -212°F are used for monitoring of system's operation temperatures for safety and verification of system's functions.
6. **Pressure Gauge:** with the range of 0 to 100 psi it allows for monitoring of system's pressure for safety and verification of system's function.

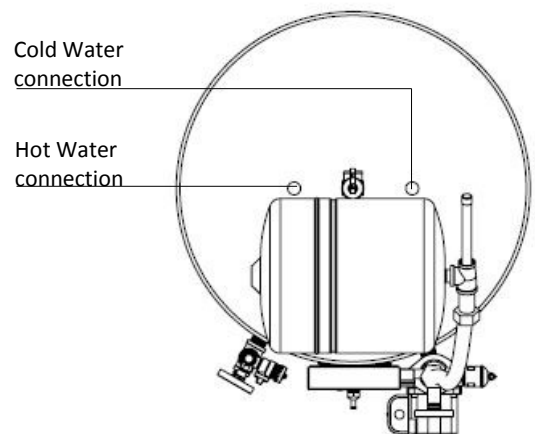
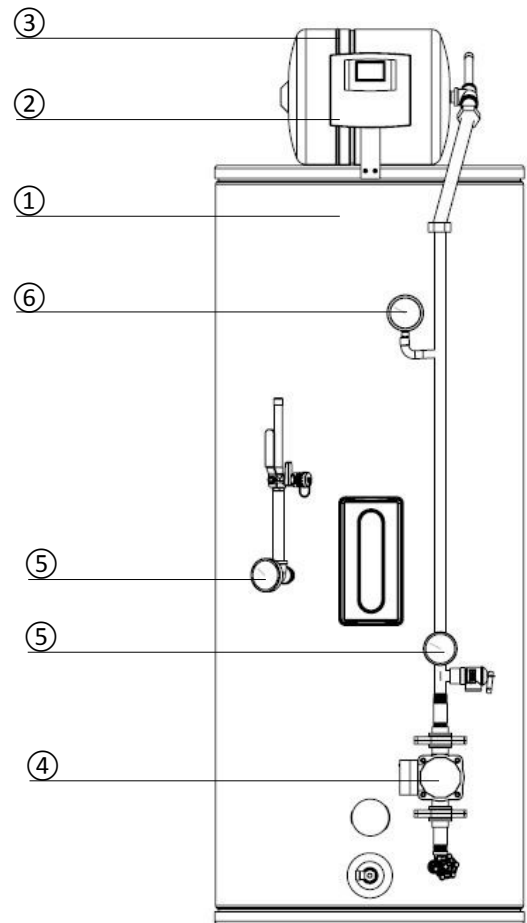

Due to SunEarth's policy of continuous product improvement, specifications are subject to change without notice.



8425 Almeria Avenue Fontana, CA 92335
(909) 434-3100, Fax (909) 434-3101
www.sunearthinc.com