

All information in this installation guide (product names and illustrations are property of Professional Solar Products, Inc. Duplication of whole or in part is strictly prohibited unless authorized by Professional Solar Products, Inc.

TOOL LIST (WHAT YOU WILL NEED):

- 3/16" Drill (Roof Pilot hole)
- 3/16" Hex (T-Wrench preferred)
- Cordless Impact
- 1/4" Drive Socket (hinge bolt connection)

The above tool list is what ProSolar recommends for installation of the Tilt Up kit along with the Tile Trac attachment. For a complete guide to installing the Roof Trac mounting system please refer to the Roof Trac installation manual.

The Roof Trac Tilt Up kit is a residential tilt up accessory for the Roof Trac solar PV mounting system. The Tilt up kit integrates with both the Tile Trac and the Fast Jack attachment methods (explained in this installation guide).

Each Tilt Up kit includes the following parts (comes in boxes of 3 kits):

- 3—1" x 1" x 24" square tube, drilled on each end
- 6—Lower (*unthreaded*) tilt-up brackets—pre tapped
- 3—Upper (*threaded*) tilt-up brackets
- 3—Upper (*hollow*) lower hinge brackets
- 12—5/16" x 2" Stainless Steel socket cap screws
- 6—3/8" x 3/4" Stainless Steel hex bolts
- 12—3/8" Stainless Steel lock washers

Each box of tilt up kits contains 3 total kits—so components will be 3x the number of parts listed above.

TILE TRAC
VERSION

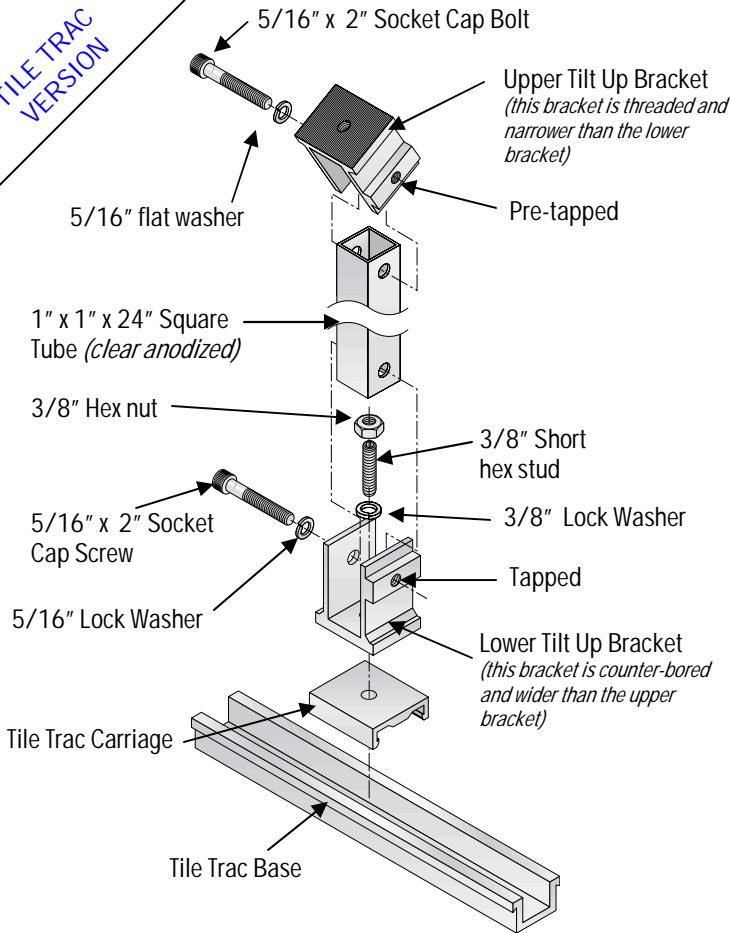

STEP 1—USING TILE TRAC ATTACH THE REAR ASSEMBLY:

A: Attach the lower (counter-bored) tilt up bracket to the Tile Trac:

Place the lower tilt up bracket (non-threaded) over the 1-1/2" stud with the serrated surface facing down. Square off with the Tile Trac upper carriage to insure a straight tilt up leg. Tighten down with a 3/8" lock washer and 3/8" hex nut. (see illustration)

B: Set in the rear Tilt Up leg (square tube):

Place the tilt up leg (square tube) in the center of the bracket. Align the holes of the tube with the holes in the lower bracket. Insert a 5/16" x 2" socket cap bolt with a lock washer through the holes. Do not tighten yet.

C: Attach the upper (tapped) tilt up bracket to the square tube: Place the upper bracket (tapped) on top of the tube. Align the holes of the tube with the holes in the lower bracket. Insert a 5/16" x 2" socket cap bolt with a lock washer through the holes. Do not tighten yet.

TILE TRAC
VERSION

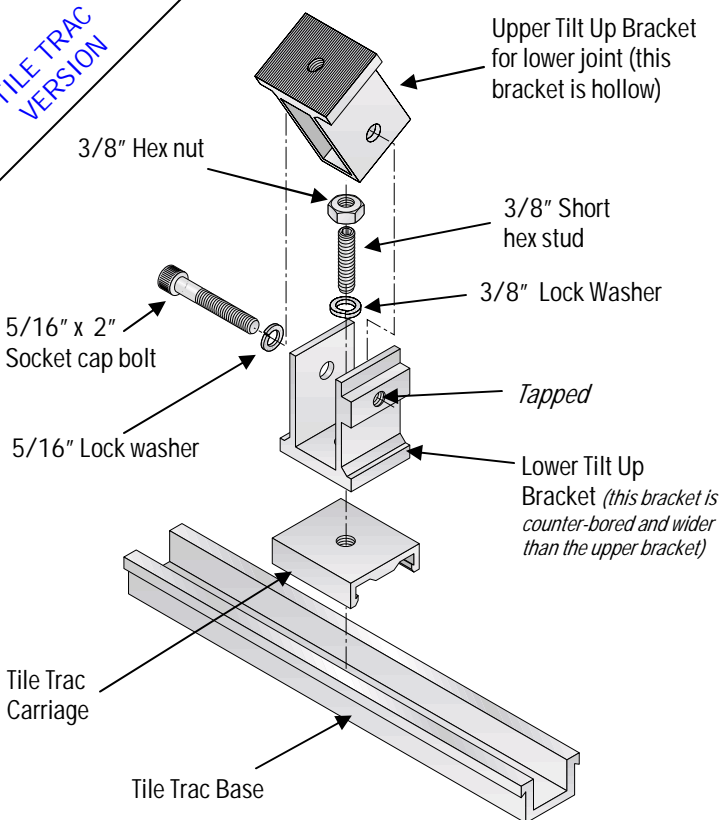

STEP 2—WHEN USING THE TILE TRAC ATTACH THE FRONT LEG ASSEMBLY:

A: Attach the lower (counter-bored) tilt up bracket to the Tile Trac:

Place the lower tilt up bracket (counter-bored) over the 1-1/2" stud with the serrated surface facing down. Square off with the Tile Trac to ensure a straight tilt up leg. Tighten down with a 3/8" lock washer and 3/8" hex nut. (see illustration)

B: Attach the upper (hollow) tilt up bracket to the lower bracket: Place the upper bracket (hollow) inside of the lower bracket. Align the holes of the upper bracket with the holes in the lower bracket. Insert a 5/16" x 2" socket cap bolt with a lock washer through the holes. Do not tighten yet.

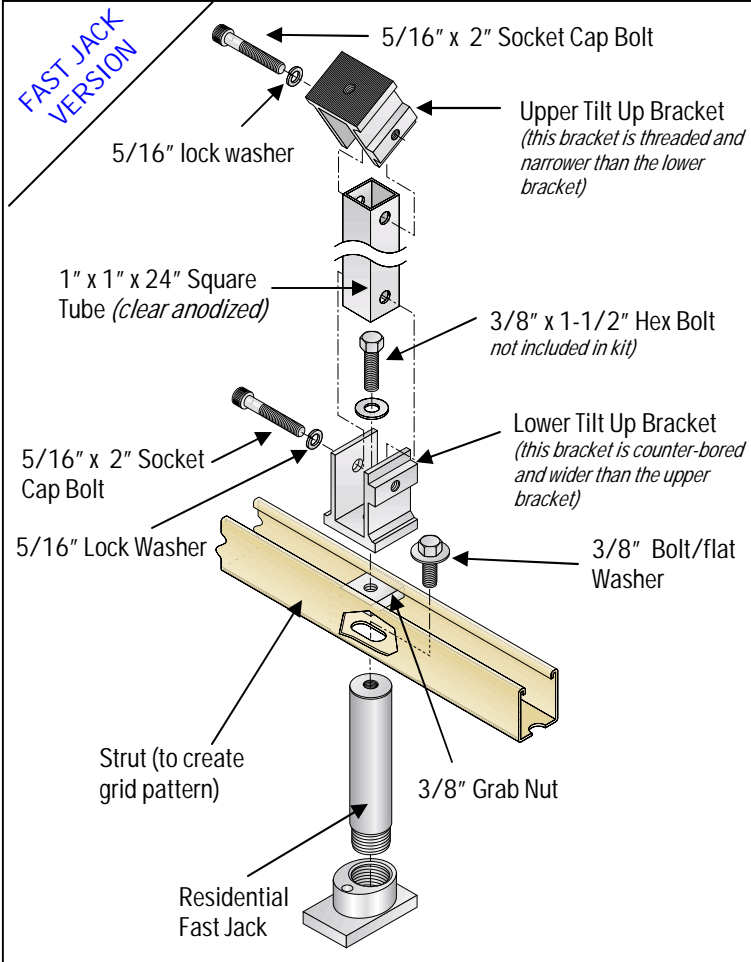

STEP 1—USING FAST JACK ATTACH THE REAR ASSEMBLY:

A: Attach the lower (counter-bored) tilt up bracket to the strut/beam:

Place the lower tilt up bracket (non-threaded) over the 3/8" threaded grab nut with the serrated surface facing down. Square off with the strut to insure a straight tilt up leg. Tighten down with a 3/8" lock washer. (see illustration)

B: Set in the rear Tilt Up leg (square tube):

Place the tilt up leg (square tube) in the center of the bracket. Align the holes of the tube with the holes in the lower bracket. Insert a 5/16" x 2" socket cap bolt with a lock washer through the holes. Do not tighten yet.

C: Attach the upper (tapped) tilt up bracket to the square tube: Place the upper bracket (tapped) on top of the tube. Align the holes of the tube with the holes in the lower bracket. Insert a 5/16" x 2" socket cap bolt with a lock washer through the holes. Do not tighten yet.

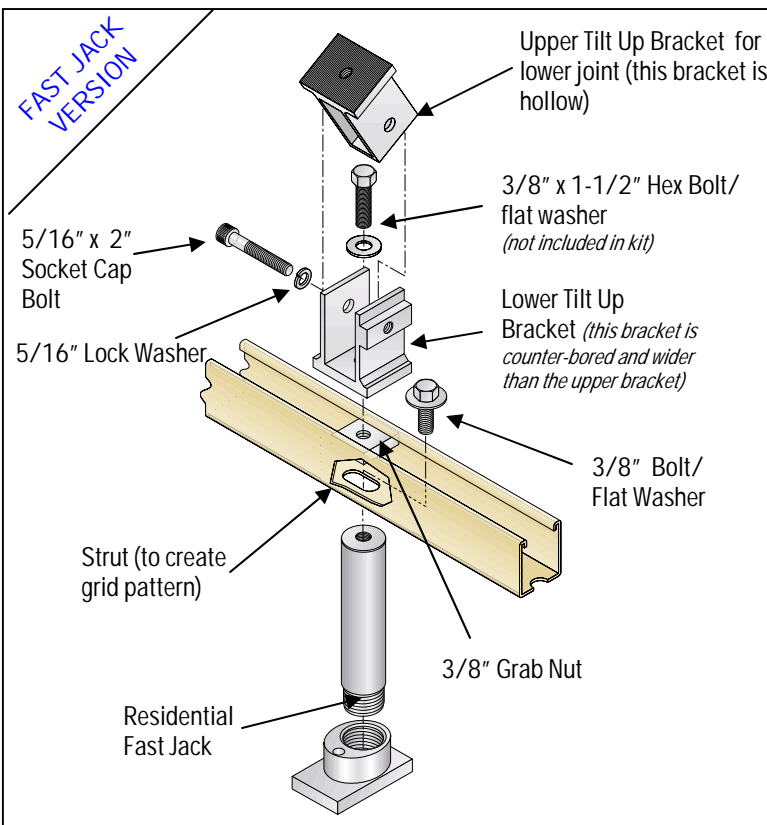

STEP 2—WHEN USING THE FAST JACK ATTACH THE FRONT LEG ASSEMBLY:

A: Attach the lower (counter-bored) tilt up bracket to the strut:

Place the lower tilt up bracket (non-threaded) over the grab nut with the serrated surface facing down. Square off with the strut to ensure a straight tilt up leg. Tighten down with a 3/8" lock washer and 3/8" hex bolt combination. (see illustration)

B: Attach the upper (hollow) tilt up bracket to the lower bracket: Place the upper bracket (hollow) inside top of the lower bracket. Align the holes of the upper bracket with the holes in the lower bracket. Insert a 5/16" x 2" socket cap bolt with a lock washer through the holes. Do not tighten yet.

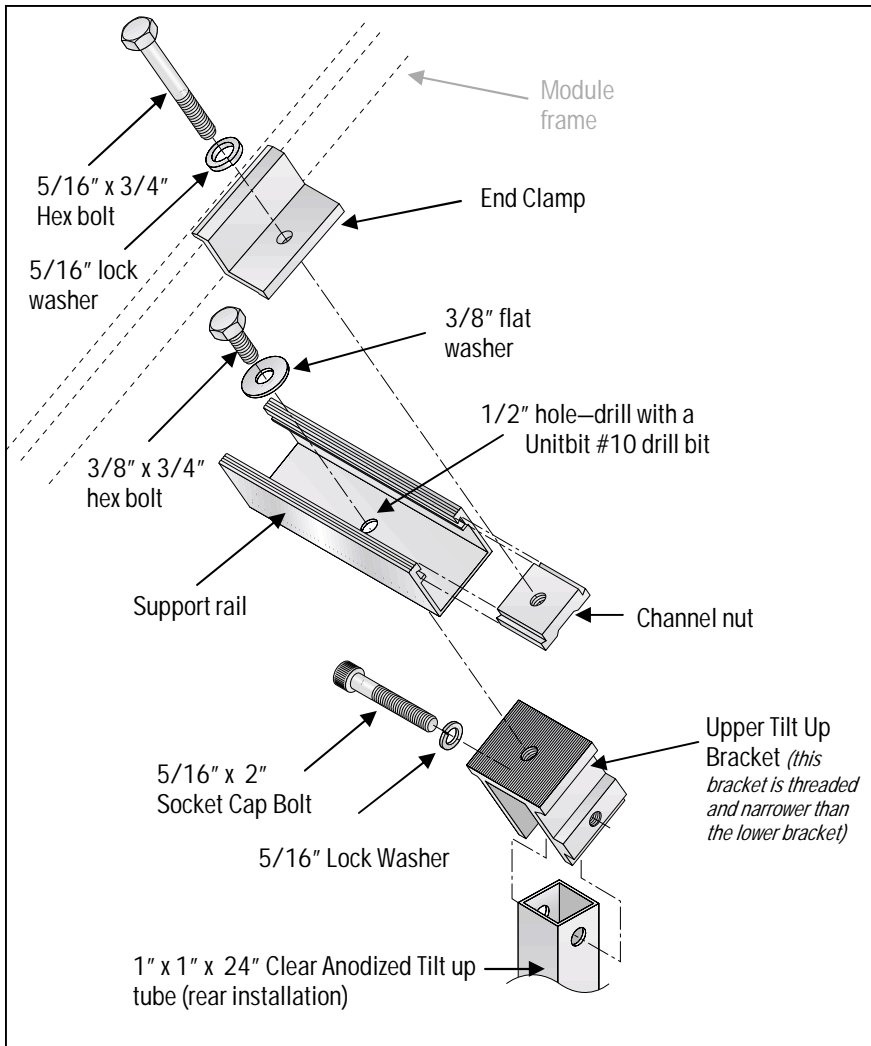

STEP 3—ATTACH THE SUPPORT RAILS (not included in tiltup kit) TO THE TILT UP ASSMBLY:

A: Drill your holes in the support rail: Mark your spacing of the attachment points on the underside of the rail (the v-groove marks the center of the rail). With a #10 Unibit drill bit drill a 1/2" hole in the support rail

B: Attach the support rail to the bracketing: Align the holes of the support rail to the holes of the upper tilt up brackets. Insert the 3/8" x 1" bolt and flat washer and tighten using 20 ft. lbs. Repeat for both upper and lower tilt up assemblies.

C: Tilt up system to desired angle: Hold the rear tilt up array to the desired angle. Tighten all bracketing connections using 20 ft. lbs. When the rear assembly is set at the desired angle, set the angle of the front bracket assembly and tighten using 20 ft. lbs.

When installing the Tilt Up kit be sure to refer closely to the load testing and engineering specifications for adequate spacing guidelines.

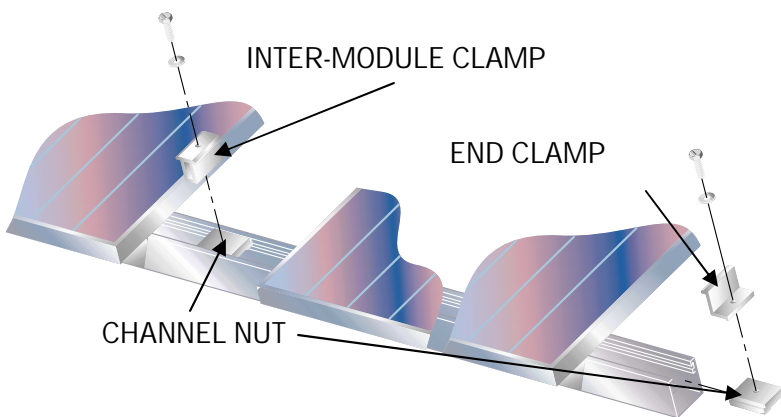

Please note that all module end clamps are proprietary and specially extruded to fit a specific brand of module. Since many of these tolerances are very small, we install a die line (marker) to differentiate the correct die per module frame.

MODULE CLAMP ASSEMBLY DETAIL

After the support rails have been installed to the attachments, you are now ready to install the solar modules. There are two sets of clamps; the outside clamps (end clamp) and the inter-module clamps that install between the modules. For convenience, it is advisable to pre-thread or start the bolt, lock washer and clamp into the sliding insert prior to bringing them up to the roof. Slide the two end clamps near the end of the support rail and install your end module (first). Carefully square the module to the frame and tighten the clamps using a 1/2" box wrench or drive socket. **DO NOT OVER-TIGHTEN**, we recommend a maximum torque of 12 foot pounds to prevent damage to the module glass. After the first module is secured, slide two inter-module clamp sets onto the first module. They are designed to stay in place freeing you up to slide and align the next module into place. Repeat this procedure until all modules are installed onto the support rail. Upon installation of the last module in the panel, install the module end clamp to complete the installation.