

SOLAR COLLECTORS

The new GOBI has undergone a complete transformation for 2011 making it the industry's best flat plate collector. By redesigning the frame and incorporating state of the art components, the GOBI has a reduced profile and even better performance. With 3 sizes and 2 absorber surface types to choose from, there is a GOBI collector for every type of solar water heating application.

Thinnest Profile – The redesigned frame is easier to handle for installers and offers the end user a streamlined, sleek look on their roof compared to bulky traditional flat plate collectors.

Rated Top Performance – New SRCC ratings certify that the GOBI now ranks among the best OG-100 collectors. The high energy output of the GOBI offers maximum performance out of the solar hot water system.

Easiest to Install – The GOBI retains its unique Dyn-O-Seal (DOS) union interconnection method. DOS unions come factory assembled and eliminate the time consuming task of soldering each collector together in an array.

New Design Features

- 1" reduction in frame thickness
- Improved insulation
- Full plate absorber
- Rounded edge profile
- OG-100 certified with higher performance and efficiency



DOS unions are included to connect and cap off collectors

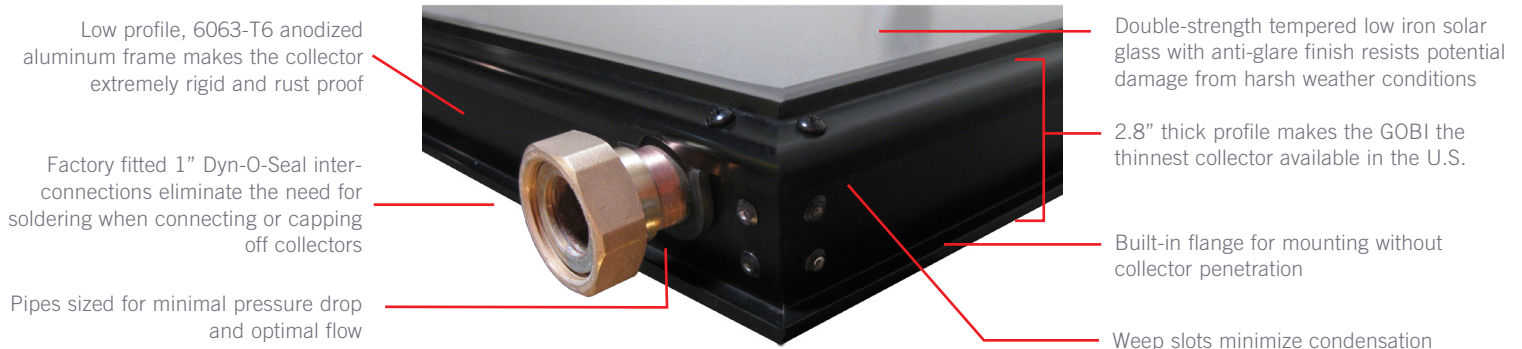

TECHNICAL SPECIFICATIONS

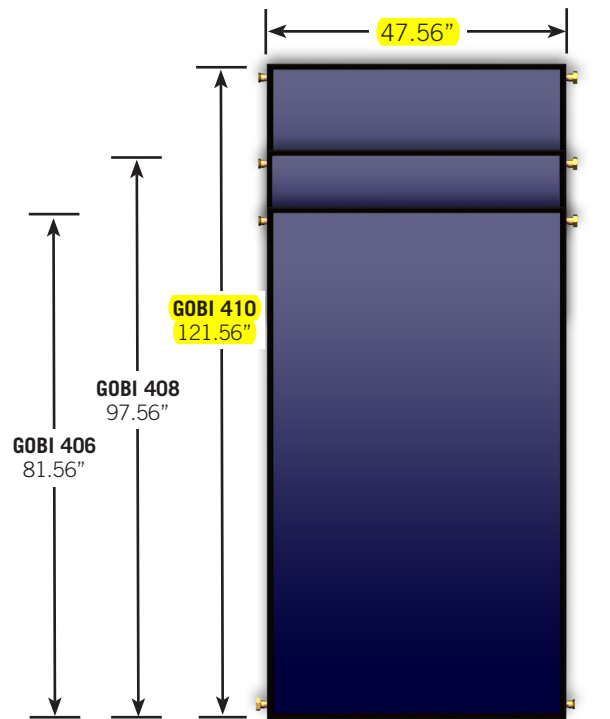
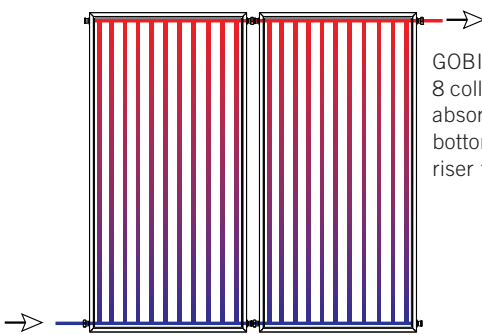
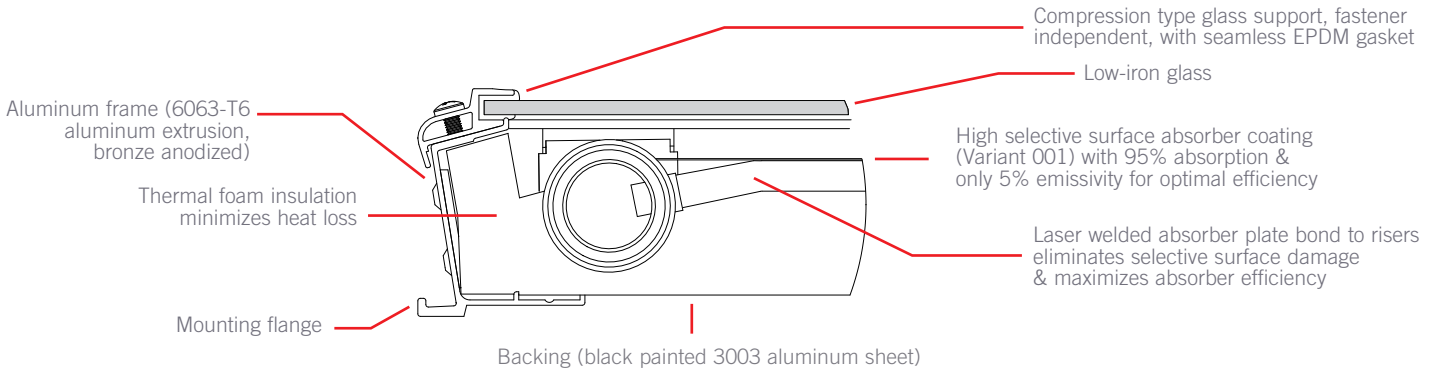

NOTE: GOBIs all have a depth of 2.8"

SRCC SRCC OG-100 RATINGS (CLEAR DAY)

Category (Ti-Ta)	GOBI 406 001	GOBI 408 001	GOBI 410 001
Certification Number	2010115C	2010115D	2010115A
A (-9°F)	38.3	46.2	57.6
B (9°F)	34.9	42.0	52.4
C (36°F)	29.7	35.8	44.7
D (90°F)	20.3	24.5	30.7
E (144°F)	12.0	14.6	18.2

TECHNICAL SPECIFICATIONS

	GOBI 406	GOBI 408	GOBI 410
Gross Area	26.94 ft ²	32.23 ft ²	40.15 ft ²
Net Area	24.91 ft ²	29.83 ft ²	38.3 ft ²
Dry Weight	98 lbs.	110 lbs.	127 lbs.
Fluid Capacity	0.6 gal	0.7 gal	0.8 gal
Maximum Operating Pressure	150 psi (10.34 Bar)		
Recommended Design Flow Rate (glycol/water mix)	0.8 gal/min	1.0 gal/min	1.25 gal/min
Recommended Design Flow Rate (water)	0.7 gal/min	0.8 gal/min	1.0 gal/min
Wind Load Certification	82 psf		

1033_0328_US © 2011 Heliodyne, Inc. • Heliodyne® and Excellence by Design® are registered trademarks of Heliodyne, Inc.

Heliodyne, Inc. • 4910 Seaport Avenue • Richmond, CA 94804
 T: 510.237.9614 • F: 510.237.7018 www.heliodyne.com
 Information and Support: info@heliodyne.com

heliodyne
 SOLAR HOT WATER